

BOTTOM MOUNTED DRIVE

STANDARD DUTY V-GUIDED HORIZONTAL-TO-INCLINE PARTS and BULK MATERIAL HANDLING CONVEYOR

A conveyor offering both horizontal and incline capabilities for use in parts handling/separator applications and for bulk products like sludge, scrap or nuts, bolts or washers. Its mobile and features a low profile infeed for easy placement under existing machines. The frame and pulleys are grooved/notched to provide a track for the rubber vulcanized belt. This “guided” system keeps the belt centered for side loading, long run and short but wide applications

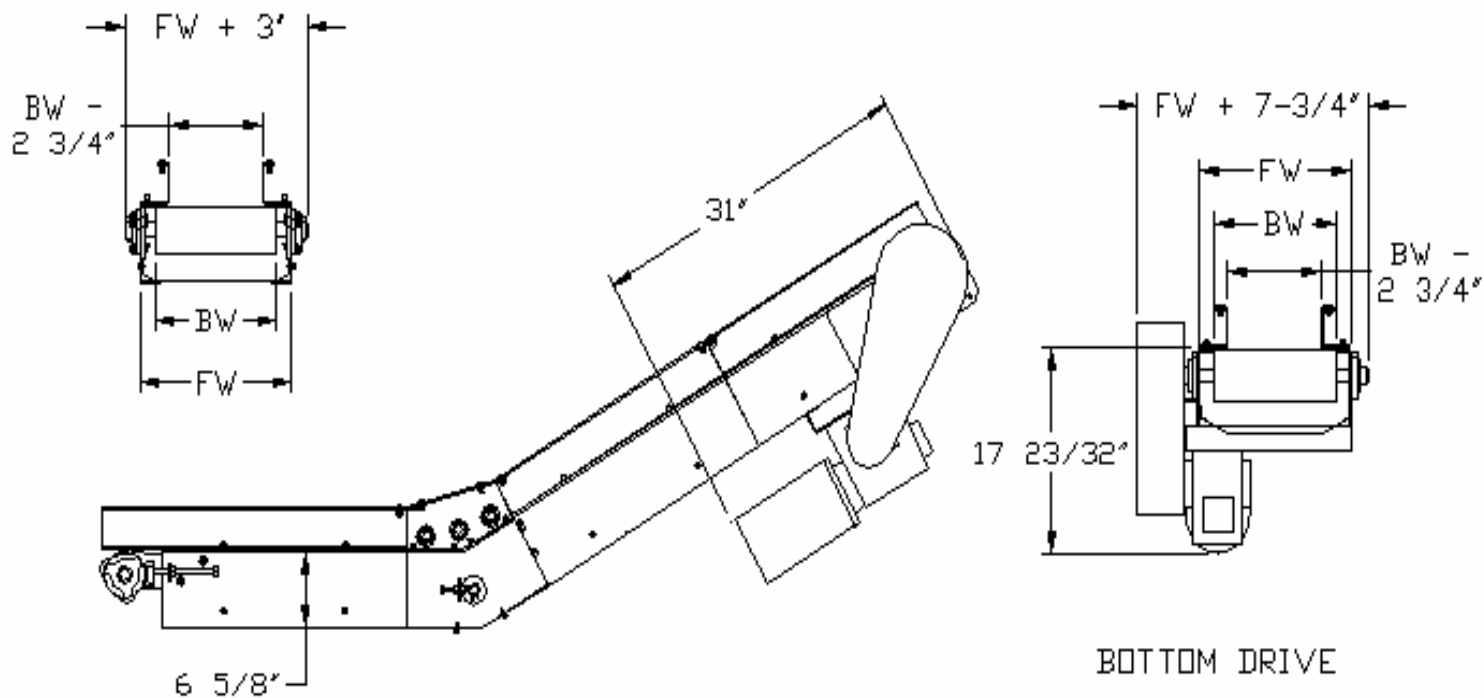

BOTTOM MOUNT DRIVE

1700 Division Street, New London, WI 54961

Phone: (800) 437-1994

Fax: (920) 982-6800

www.nleco.com